

Description

The DL0502PN is an Uni-directional TVS diode, utilizing leading monolithic silicon technology to provide fast re-sponse time and low ESD clamping voltage, making this device an ideal solution for protecting voltage sensitive high-speed data lines. The DL0502PN has an ultra-low capacitance with a typical value at 0.2pF, and complies with the IEC 61000-4-2 (ESD) with $\pm 25\text{kV}$ air and $\pm 20\text{kV}$ contact discharge. It is assembled into an ultra-small 1.2x1.0x0.5mm lead-free DFN package. The small size, ultra-low capacitance and high ESD surge protection make DL0502PN an ideal choice to protect cell phone, digital visual interfaces and other high speed ports.

- Ultra low leakage: nA level
- Low operating voltage: 5V
- Low clamping voltage
- 6-pin leadless package
- Up to 2-line protects
- Complies with following standards:
 - IEC 61000-4-2 (ESD) immunity test
Air discharge: $\pm 25\text{kV}$
Contact discharge: $\pm 20\text{kV}$
 - IEC61000-4-5 (Lightning) 3A (8/20 μs)
- RoHS Compliant

Dimensions and Pin Configuration

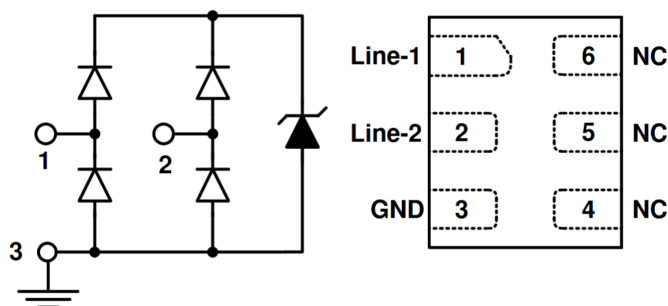

Mechanical Characteristics

- Package: DFN1210-6
- Case Material: "Green" Molding Compound.
- Terminal Connections: See Diagram Below
- Marking Information: See Below

Applications

- Cellular Handsets and Accessories
- USB Ports
- Digital Visual Interface
- MMC/SD Ports

Marking Information



52N = Device Marking Code
Dot denotes Pin1

Ordering Information

Part Number	Packaging	Reel Size
DL0502PN	3000/Tape & Reel	7 inch

Absolute Maximum Ratings ($T_A=25^\circ\text{C}$ unless otherwise specified)

Parameter	Symbol	Value	Unit
Peak Pulse Power (8/20 μs)	Ppk	50	W
Peak Pulse Current (8/20 μs)	I _{PP}	3	A
ESD per IEC 61000-4-2 (Air)	V _{ESD}	± 25	kV
ESD per IEC 61000-4-2 (Contact)		± 20	
Operating Temperature Range	T _J	-55 to +125	$^\circ\text{C}$
Storage Temperature Range	T _{stg}	-55 to +150	$^\circ\text{C}$

Electrical Characteristics ($T_A=25^\circ\text{C}$ unless otherwise specified)

Parameter	Symbol	Min	Typ	Max	Unit	Test Condition
Reverse Working Voltage	V _{RWM}			5	V	
Breakdown Voltage	V _{BR}	6			V	I _T = 1mA
Reverse Leakage Current	I _R			0.2	μA	V _{RWM} = 5V
Clamping Voltage	V _C			10	V	I _{PP} = 1A (8 x 20 μs pulse), any I/O pin to ground
Clamping Voltage	V _C			17	V	I _{PP} = 3A (8 x 20 μs pulse), any I/O pin to ground
Junction Capacitance	C _J		0.2		pF	V _R = 0V, f = 1MHz, any I/O pin to ground

Typical Performance Characteristics (TA=25°C unless otherwise Specified)

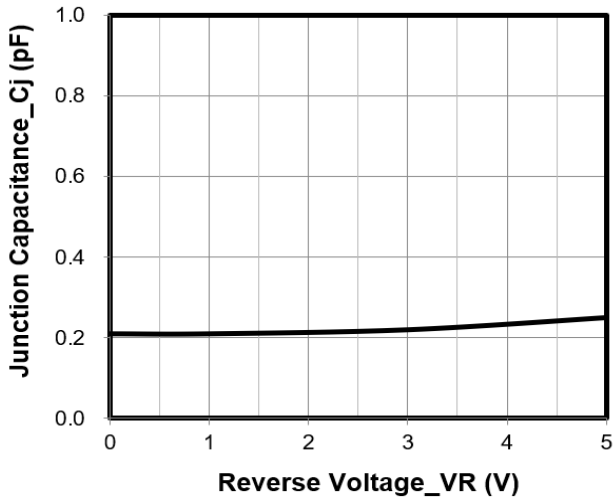

Junction Capacitance vs. Reverse Voltage

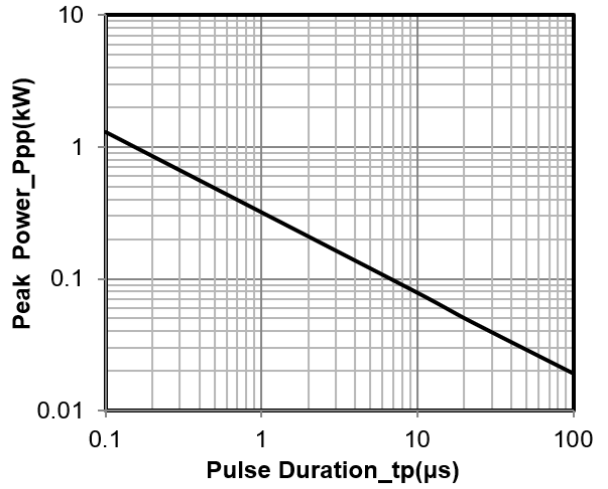

Peak Pulse Power vs. Pulse Time

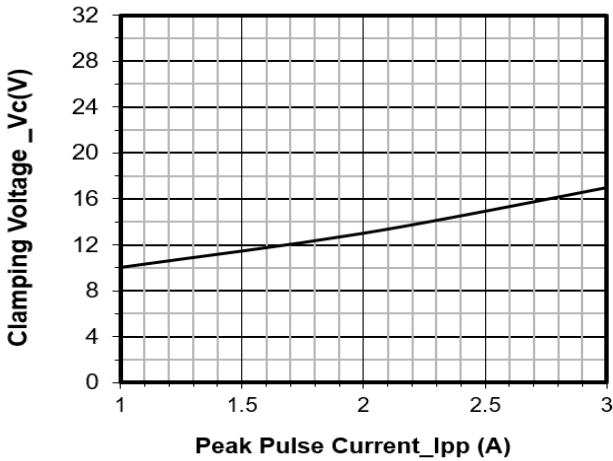

Clamping Voltage vs. Peak Pulse Current

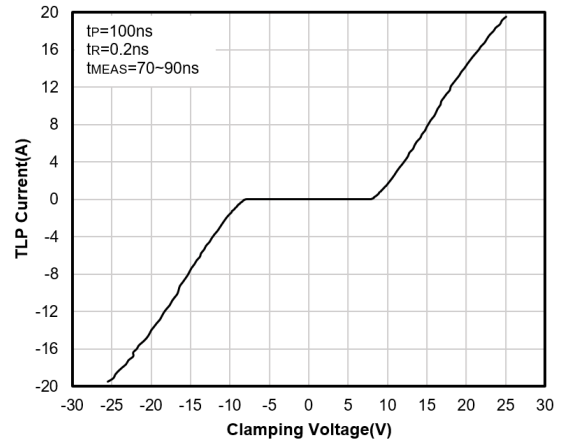

TLP Curve

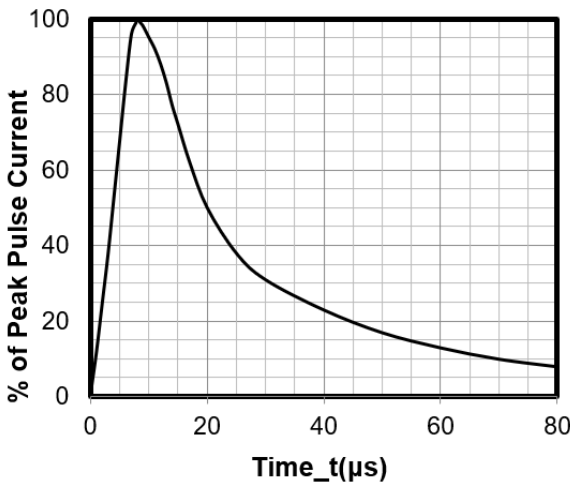

8 X 20μs Pulse Waveform

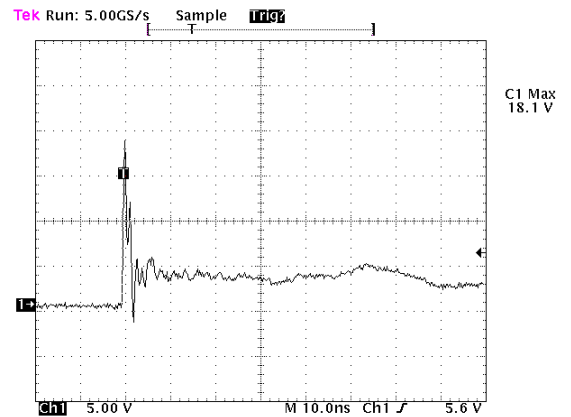

Note: Data is taken with a 10x attenuator

ESD Clamping Voltage

8 kV Contact per IEC61000-4-2

DFN1210-6 Package Outline Drawing

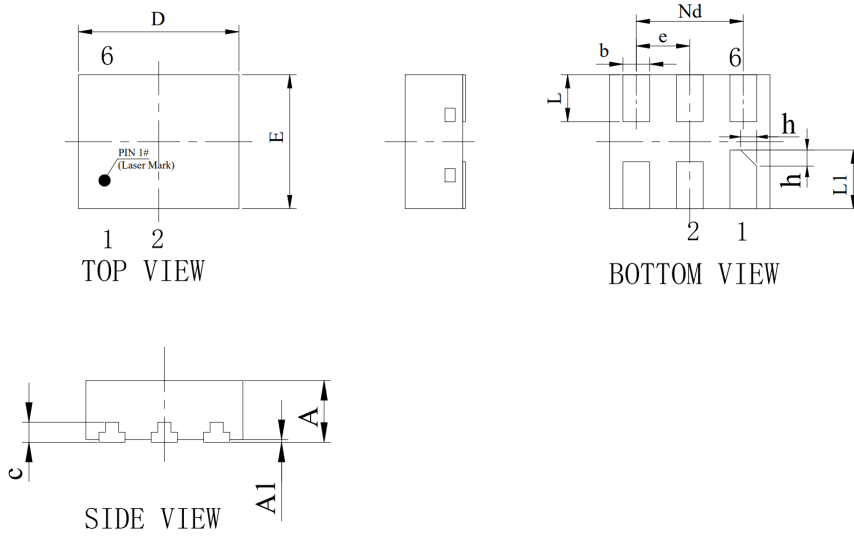

SYM	DIMENSIONS		
	MILLIMETERS		
	MIN	NOM	MAX
A	0.40	0.45	0.50
A1	0	0.02	0.05
b	0.15	0.20	0.25
c	0.152REF		
D	1.15	1.20	1.25
e	0.40BSC		
Nd	0.80BSC		
E	0.95	1.00	1.05
L	0.25	0.35	0.45
L1	0.338	0.438	0.538
h	0.07	0.12	0.17

Contact Information

Changzhou D-first Electronics CO.,Ltd.

www.first-electronic.com

Email: xhf@first-electronic.cn

Phone: +86 (0519) 8817 1671